

The Navatek Adaptive Ride Enhancement System (ARES<sup>®</sup>) incorporates the Navatek Aft Lifting Body (ALB) with Navatek's state of the art ride control system. For small craft designed to 40-plus knots, it can provide effective dynamic motion mitigation reducing both crew and equipment exposure to shock in an offshore environment. The ARES system can be fitted to new builds, or retro-fitted to many different types of existing hulls.

The ARES system is the culmination of three decades of research and work in the design, construction, and testing of underwater lifting bodies and control systems for fast ships and high speed small craft for which Navatek has become the recognized world leader. Navatek's patented lifting bodies are cambered foil sections that generate dynamic lift at speed. When installed on a high performance hull an ALB can significantly reduce motions across a wide speed range, dramatically improving ride quality. An ALB can be used on conventional monohulls or multi-hulls as well as advanced hull forms.

With its active control of the vessel's trim, an ARES system can reduce vertical accelerations by 35 percent and slamming by as much as 60 percent. The ARES electronics are all solid-state components built to withstand the abuse of the high speed craft environment. Operator interfaces are simple and intuitive, including elegant controls and display.

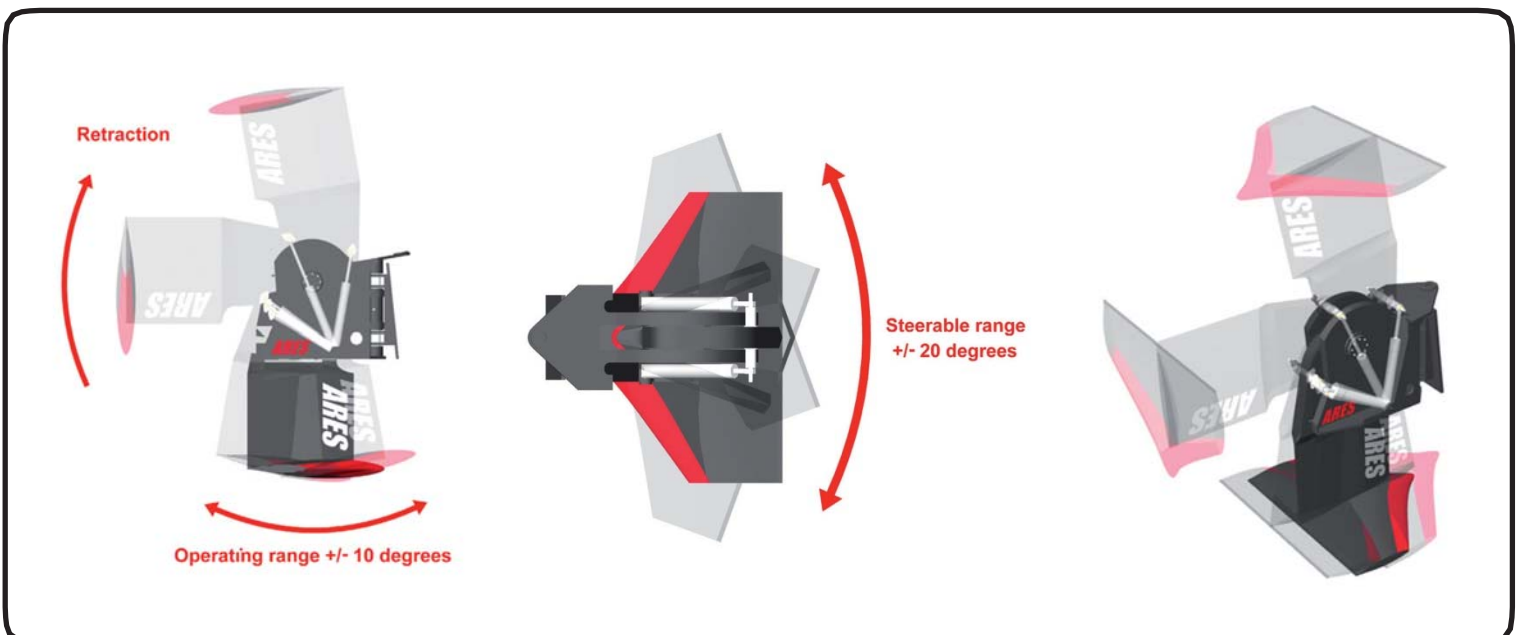
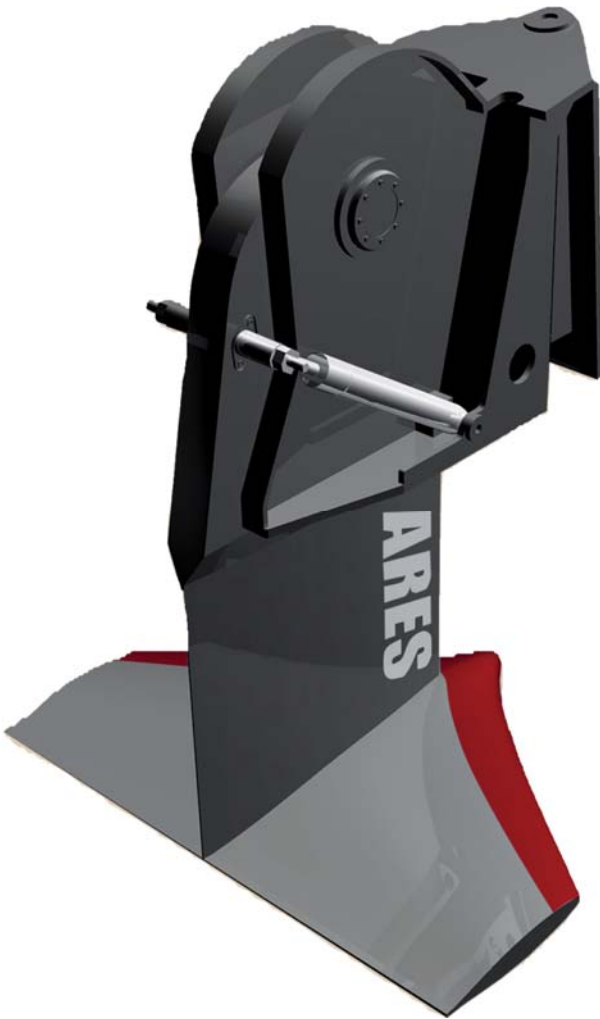

## ARES® ALB BENEFITS

- Up to 60% reduction in “slamming”
- Up to 35% overall reduction in RMS vertical accelerations
- Ability to control trim to reduce stuffing in a following seaway, and reduced accelerations in head seas
- Significantly reduced roll and pitch motions
- Increased directional stability
- Fully steerable for increased maneuverability
- Fully retractable for shallow water & maximum calm water speed
- Boat less sensitive to payload arrangement and able to get on plane with more payload
- Increased hull efficiency at low speeds by controlling vessel trim
- As wave size increases ARES benefits will increase
- Up to 5 knots faster in a sea state 3 seaway than the same boat without the ARES system.

## ARES SYSTEM COMPONENTS



Examples of ARES installations

## CASE STUDY : 1m waves Head Seas

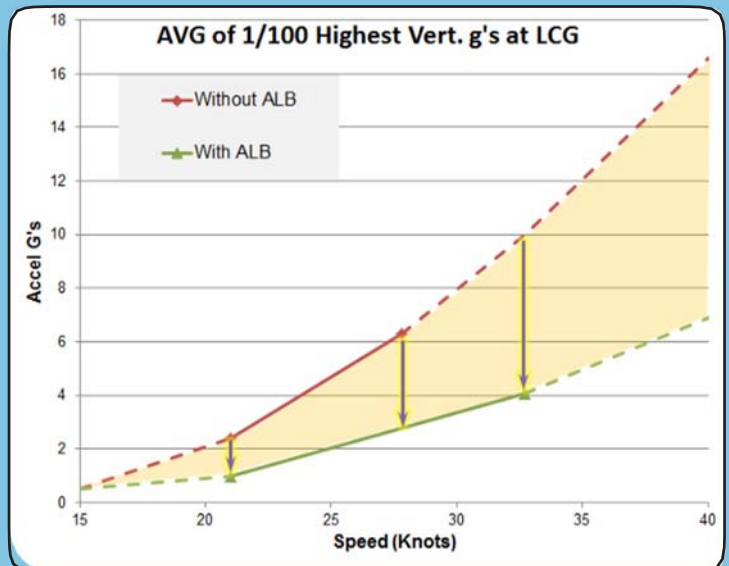
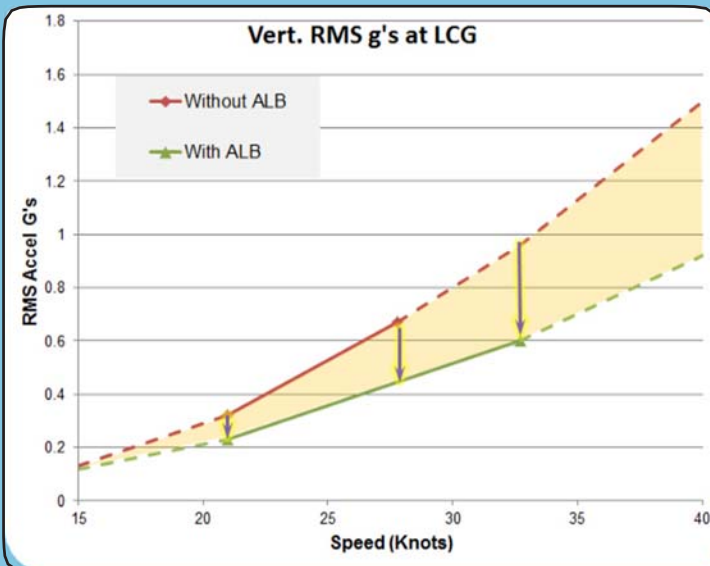

DATA MEASURED	REDUCTION
RMS Vert. Acceleration (g)	35%
Roll Angle Std. Dev. (deg)	58%
Pitch Angle Std. Dev. (deg)	44%
# of Impact Events	39%

## NAVATEK LTD

841 Bishop St, Suite 1110

Honolulu, HI 96813

USA Telephone: 808-695-6643

Toll Free: 866-531-7004 ext 14

Fax: 808-523-7668